

BT27

SRD TX SAW ISM 433.050 – 434.790 MHz

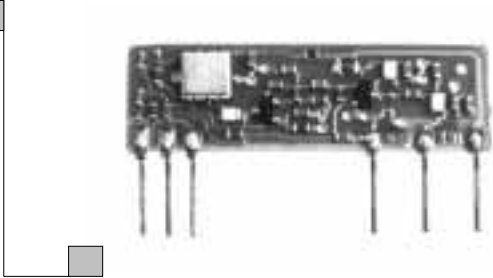

TABLE 1 - BT27 VERSIONS

BT27A5-G2	433,425 MHz	5VDC	15 mW	OOK	2.4 KB
BT27A5-G4 (1)	433,925 MHz	5VDC	15 mW	OOK	2.4 KB
BT27A5-G6	434,425 MHz	5VDC	15 mW	OOK	2.4 KB
BT27S5-G2	433,425 MHz	5VDC	15 mW	GASK	38.4 KB
BT27S5-G4 (1)	433,925 MHz	5VDC	15 mW	GASK	38.4 KB
BT27S5-G6	434,425 MHz	5VDC	15 mW	GASK	38.4 KB
BT27A3-G2	433,425 MHz	3VDC	12mW	OOK	2.4 KB
BT27A3-G4	433,925 MHz	3VDC	12 mW	OOK	2.4 KB
BT27A3-G6	434,425 MHz	3VDC	12 mW	OOK	2.4 KB
BT27S3-G2	433,425 MHz	3VDC	12 mW	GASK	38.4 KB
BT27S3-G4	433,925 MHz	3VDC	12 mW	GASK	38.4 KB
BT27S3-G6	434,425 MHz	3VDC	12 mW	GASK	38.4 KB

NOTE (1) : STANDARD VERSIONS WITH EX STOCK AVAILABILITY.
 PLEASE CONTACT THE FACTORY FOR SAMPLES AND AVAILABILITY OF NON STANDARD VERSIONS.

- SAW RESONATOR CONTROLLED.
- HIGH POWER (15 mW).
- OOK AND GASK MODULATION.
- FAST DATA RATE (38.4 KB "S" model).

DESCRIPTION:

The BT27 is a two stage "SAW" controlled data transmitter module operating on the 433.05-434.79 MHz ISM band. The module has a high (15mW) output RF power to allow the employ of poor efficiency antennas (¼ wave whip, helical or a trace on a PCB) to remain under the legal 10mW ERP limit. The BT27A version is OOK modulated whereas the BT27S employs an advanced ASK Gaussian shaped (GASK) modulation with a speed rate up to 38.4 KB.

BT27A OOK MODULATION

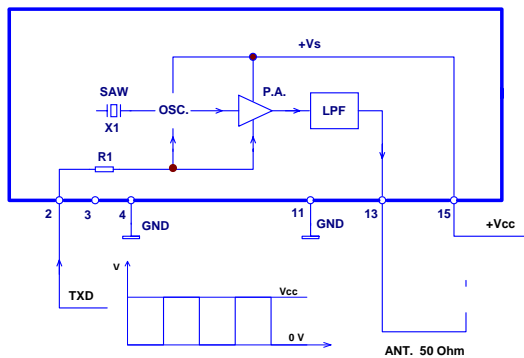

BT27S GASK MODULATION

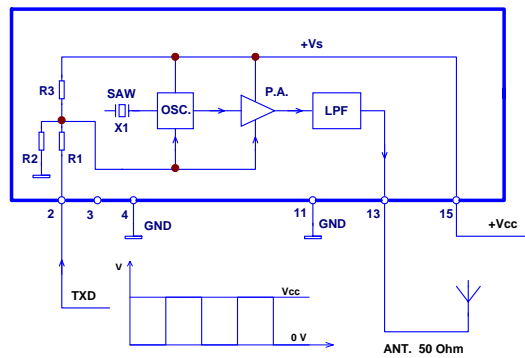
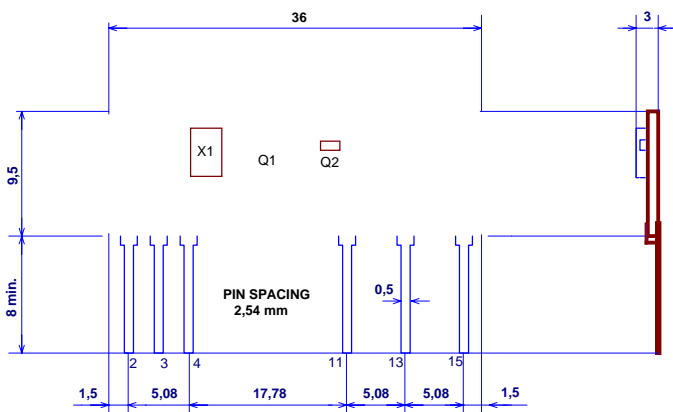

Fig.1 – BT27 BLOCK DIAGRAM.

BT27 - PERFORMANCE DATA

	Min	Typ	Max	Units	Notes
▪ FREQUENCY	433.050		434.790	MHz	
▪ RF POWER	12	15		mW	(1)
	10	12		mW	(1)
▪ IMPEDANCE		50		Ω	
▪ FREQUENCY ACCURACY		± 50	± 100	KHz	(2)
▪ HARMONIC EMISSIONS		-36	-30	dBm	
▪ DATA RATE:		1.2	2.4	KB	(3)
			38.4		
▪ SUPPLY VOLT.	4.5	5	5.5	V	
	2.75	3	3.5	V	
▪ SUPPLY CURRENT		12	14	mA	(3)
▪ SUPPLY CURRENT - CW		22	28	mA	
▪ OPERATING TEMPERATURE	-20		+60	$^{\circ}\text{C}$	

NOTE :
 (1) Max. legal ERP = 10 mW – antenna system with a radiating efficiency of 70% or less must be employed.
 (2) Over operating temperature range.
 (3) 50 / 50 MARK / SPACE DATA PATTERN.



PIN DESCRIPTION		
PIN 2	TXD	DATA INPUT
PIN 3	N.U.	
PIN 4	GND	GROUND
PIN 11	GND	RF GROUND
PIN 13	ANT	RF OUTPUT
PIN 15	VCC	DC SUPPLY

Fig.2 – BT27 PHYSICAL DIMENSIONS.

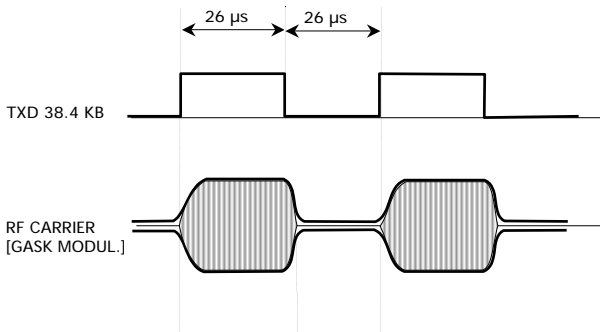

Fig.3 – BT27S- GASK (GAUSSIAN SHAPED AMPLITUDE SHIFT KEYING).

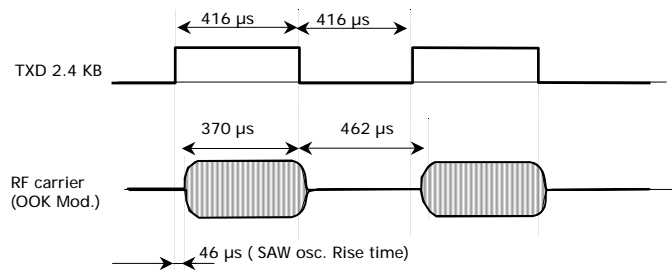

Fig.4 – BT27A - OOK (ON-OFF KEYING) MODULATION.

NOTE:

The BT27A is designed for transmitter system where the DC supply is permanently connected to the module itself. When data (TXD) is zero the current falls below less than 1 μA .

Max. data speed is limited by the oscillation start-up time of the SAW resonator.

